



# FOOD EQUIPMENT

SERVING THE FOOD INDUSTRY SINCE 1951

## 12" BELT-DRIVEN AUTOMATIC SLICER

Item: 13654

Model: MS-IT-0300-A



**1 YEAR** LIMITED WARRANTY  
PARTS AND LABOR

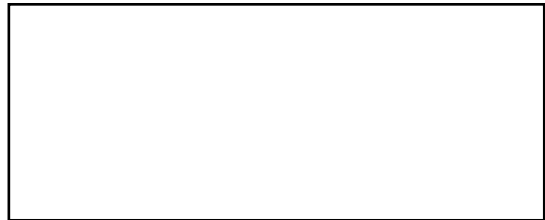

Authorized Dealer



# FOOD EQUIPMENT

## 12" BELT-DRIVEN AUTOMATIC SLICER



Belt-driven gravity automatic slicer, equipped with two separated fan-cooled motors: one operating the blade, the other one operating the carriage. Designed in anodized aluminium alloy, red plastic parts, knobs and feet, tempered chromium steel blade. Thanks to slicer's adjustable carriage stroke and available options, this unit meets any requirement and allows professionals to slice in less time.

This model also features a removable aluminium blade cover, product holder, pusher, and stainless steel slice deflector. It is also equipped with a removable sharpener, fixed blade ring guard, and removable product holder. Comes with 1 year warranty.

### TECHNICAL DRAWING AND DIMENSIONS

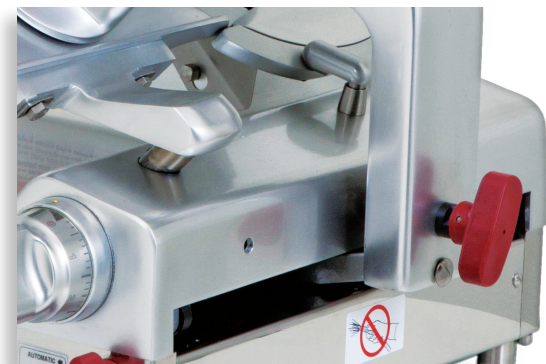
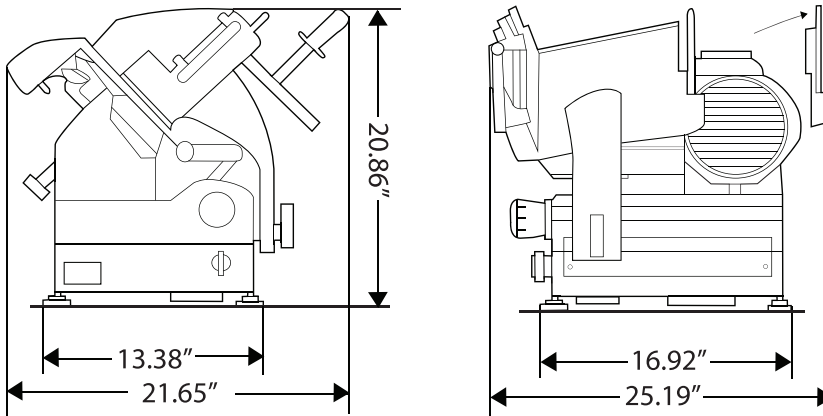

### TECHNICAL SPECIFICATION

ITEM NUMBER	13654
MODEL	MS-IT-0300-A
BLADE SIZE	12"/300mm
POWER	0.50 HP / 0.37kW (x2)
CHEESE SLICING*	
SLICING VOLUME*	8 hours or more
RPM	200
CUTTING SIZE	8.85" x 8.66"/ 22.5 x 22 cm
CUT THICKNESS	0"-0.6"/ 0-14mm
ELECTRICAL	120V/60/1
WEIGHT	90.2 lbs./ 41 kg.
PACKAGING WEIGHT	103.4 lbs./ 47 kg.
DIMENSIONS (WDH)	25.19" x 21.65" x 20.86"/ 64 x 55 x 53 cm
PACKAGING DIMENSIONS	28.34" x 25.60" x 30.13"/ 72 x 65 x 77 cm

Safety options available. Belt driven. In compliance with Province of Quebec Safety Standards  
Results may vary due to product consistency and temperature

## OMCAN INC.

Telephone: 1-800-465-0234  
Fax: (905) 607-0234  
Email: [sales@omcan.com](mailto:sales@omcan.com)  
Website: [www.omcan.com](http://www.omcan.com)



Follow us to keep up to date with the latest news and offers



2015.E.O.E